

Journal of Applied Environmental and Biological Sciences (JAEBS)



An International Peer-reviewed journal

Number of issues per year: 12

ISSN (Print): 2090-4274

ISSN (Online): 2090-4215

[Home](#)[Journals](#)[Contact Us](#)

TEXTROAD JOURNALS

Journal of Applied Environmental and Biological Sciences



J. Appl. Environ. Biol. Sci., Vol.7 No. 12: pp. 1-346, Year 2017

Journal of Applied Environmental and Biological Sciences (JAEBS)

Monthly Publication



Number of issues per year: 12

ISSN: 2090-4274 (Print)

ISSN: 2090-4215 (Online)

Journal of Applied Environmental and Biological Sciences (JAEBS) is a peer reviewed, open access international scientific journal dedicated for rapid publication of high quality original research articles as well as review articles in the all areas of Applied Environmental and Biological Sciences.

Scope

Journal of Applied Environmental and Biological Sciences (JAEBS) is devoted to the monthly publication of research papers of outstanding significance in the all fields of environmental sciences, environmental engineering, environmental Pollution, green chemistry, environmentally friendly synthetic pathways, alternatively fuels, environmental analytical chemistry, biomolecular tools and tracers, water and soil, environmental [management, economics, humanities], Mathematics, multidisciplinary aspects such as Business Management, Organizational Behavior, all areas of biological sciences, including cell biology, developmental biology, structural biology, microbiology, molecular biology & genetics, biochemistry, biotechnology, biodiversity, ecology, marine biology, plant biology, bioinformatics, toxicology, developmental biology, structural biology, microbiology, molecular biology & genetics, biotechnology, biodiversity and related fields. The journal presents the latest developments in the fields of environmental social marketing, environmental journalism, environmental education, sustainability education, environmental interpretation, and environmental health communication.

Editorial Board

Editor -in-Chief

William Ebomoyi

Ph.D., Professor, Department of Health Studies, College of Health Sciences, Chicago State University, **USA**.

E-mail: editor@textroad.com

Associate Editors

Prof. Dr. Sanaa T. El-Sayed

Ex Head of Biochemistry Department, Professor of Biochemistry, Genetic Engineering & Biotechnology Division, National Res Centre, **Egypt**

Saeid Chekani Azar

PhD of Veterinary Physiology; Faculty of Veterinary, Department of Physiology, Ataturk University, Erzurum 25010, **Turkey**.

Prof. Dr. Sarwoko Mangkoedihardjo

Professor, Professional Engineer of Indonesian Society of Sanitary and Environmental Engineers, **Indonesia**

Prof. Dr. Ashraf Latif Tadross

Head of Astronomy Department, Professor of Star Clusters and Galactic Structure, National Research Institute of Astronomy & Geophysics (NRIAG), 11421 Helwan, Cairo, **Egypt**.

Dr. Chandrasekar Raman

Research Associate, Department of Biochemistry & Molecular Biophysics, Biotechnology Core Facility, 238, Burt Hall, Kansa University, Manhattan 66506, KS, **USA**.

Dr. YUBAO CUI

Associate Professor, Department of Laboratory Medicine, Yancheng Health Vocational & Technical College, Jiangsu Province, P. R. **China**

Dr. Muhammad Altaf Khan

Department of Mathematics, Abdul Wali Khan University Mardan **Pakistan**

Dr. Fahrettin Tilki

Assoc. Professor, Artvin Coruh University, Faculty of Forestry, Department of Forest Science, Artvin, **TURKEY**.

Dr. Ibtisam abd el ghany hammad

Associate Professor of Genetics, Faculty of Science, Helwan University. **Egypt**.

Dr. Charalambos Tsekeris

Department of Psychology, Panteion University of Social and Political Sciences, Athens, **Greece**.

Dr. Elsayed E. Hafez

Associate Professor, Molecular Biology, Plant Molecular Pathology & Arid Lands Institute, **Egypt**.

Dr. Naushad Mamode Khan

University of Mauritius, Reduit, **Mauritius**.

Mirza Hasanuzzaman

Department of Agronomy, Faculty of Agriculture, Sher-e-Bangla Agricultural University, Dhaka-1207, **Bangladesh**.

Dr. Hala Ahmed Hafez Kandil

Professor Researcher, National Research Centre, Plant Nutrition Dept. El-Bhouth St. Dokki, Giza, **Egypt**.

Dr. Yule Yue Wang

Biotechnology and Medicinal Biochemistry, Division of Life Science, The Hong Kong University of Science & Technology, **Hong Kong**.

Dr. Aziza Sharaby

Professor of Entomology. Plant Protection Department, National Research Center. Cairo, **Egypt**.

Dr. Sulaiman

Assistant Professor, Department of Biochemistry, Abdul wali Khan University Mardan, Khyber Pakhtunkhwa, **Pakistan**.

Editors

Maulin P Shah

PhD-Microbiology, Chief Scientist & Head Industrial Waste Water Research Laboratory, Division of Applied & Environmental Microbiology, Enviro Technology Limited, Ankleshwar-393002, Gujarat, **India**

Dr. Josphert N. Kimatu

Department of Biological Sciences. South Eastern University College, **Kenya**.

Dr. Mukesh Kumar Meena

Assistant Professor (Crop Physiology), Department of Crop Physiology, University of Agricultural Sciences, Raichur-584104, Karnataka , **India**

Jehngir Khan

Lecturer in Zoology Department, Abdul Wali Khan University Mardan (AWKUM), Buner Campus, Buner, Khyber Pakhtunkhwa, **Pakistan**.

Syed Muhammad Nurulain

Medical Research Specialist, FMHS, UAE University, **Emirates**

Dr. Ayman Batisha

Environment and Climate Research Institute, National Water Research Center, Cairo, **Egypt**.

Dr. Hakeem Ullah

Assistant Professor, Department of Mathematics Abdul Wali Khan University Mardan **Pakistan**.

DR. DATTA ASARAM DHALE

Assistant Professor, Post Graduate Department of Botany, Ghogrey Science College, Dhule, Maharashtra State, **India**.

Dr. Muhammad Ismail Mohmand

Tutor/Administrator in the Excellence Training Den College in Newcastle, **United Kingdom**

Prof. Dr. Valdenir José Belinelo

Department of Health Sciences and Postgraduate Program in Tropical Agriculture, Federal University of Espirito Santo (UFES), São Mateus, ES, **Brazil**.

Siva Sankar. R

Department of Ecology and Environmental Sciences, School of Life Sciences, Pondicherry University, **India**.

Table of Contents, December 2017

Nieke Karnaningroem, Achmad Muzakky, Geodita Woro Bramanti

Identifying the Risk of Drinking Water Refill Stations in Surabaya Using Fishbone Method, Case Study in Sukolilo, Gubeng, Rungkut, and Wonocolo Subdistrict

J. Appl. Environ. Biol. Sci. 2017 7(12): 1-8. [\[Abstract\]](#) [\[Full-Text PDF\]](#) [\[Full-Text XML\]](#)

Mohamed Helal El-Sayed and Islam Abd Elmageed Elsehemy

Paenibacillus sp. strain NBR-10, A Thermophilic Soil-Isolated Bacterium with Thermo-Alkali Stable Pectinase Activity

J. Appl. Environ. Biol. Sci. 2017 7(12): 9-19. [\[Abstract\]](#) [\[Full-Text PDF\]](#) [\[Full-Text XML\]](#)

Lahouari DAHLOUM, Mabrouk DIDI, Miloud HALBOUCHE

Effects of Feeding Locally Grown Whole Barley on Broiler Performance

J. Appl. Environ. Biol. Sci. 2017 7(12): 20-26. [\[Abstract\]](#) [\[Full-Text PDF\]](#) [\[Full-Text XML\]](#)

K. N. Memon, A. M. Siddiqui, Syed Feroz Shah

Exact Solution of Tank Drainage through the Circular Pipe for Couple Stress Fluid

J. Appl. Environ. Biol. Sci. 2017 7(12): 27-34. [\[Abstract\]](#) [\[Full-Text PDF\]](#) [\[Full-Text XML\]](#)

Rahadhian Prajudi, Indri A., Y. Basuki Dwisusanto

The Architectural Creativity as a Local Genius Dialogue in the Javanese Traditional Building

J. Appl. Environ. Biol. Sci. 2017 7(12): 35-40. [\[Abstract\]](#) [\[Full-Text PDF\]](#) [\[Full-Text XML\]](#)

Zafar Jamal, Arshid Pervez, Manzoor Hussain, Ghulam Mujaba Shah, Syed Hasnain Shah, Mustajab Ahmed

Ethnomedicinal Plants used for Gastrointestinal Ailments by the Rural Communities of Kaghan Valley, Mansehra, Pakistan

J. Appl. Environ. Biol. Sci. 2017 7(12): 41-48. [\[Abstract\]](#) [\[Full-Text PDF\]](#) [\[Full-Text XML\]](#)

Munirah Onn, Raja Zuraidah Raja Mohd Rasi, Aznilinda Zainuddin, Norbaiti Sidik, Norbaiti Tukiman, Herda Balqis Ismail, Suhana Mohamed, Muhammad Haziq Zulfikri, Ariff Fahmi Mohd Azmi, Dhabit Ahmaduzzakwan Mohd Fauzi, Siti Khadijah Roslan, Nur Faradalila Zakaria, Nurul Ain Razali, Muhammad Hafiz Hizam, Mohamad Haziq Hazwan, Mohd Aizat Saad

Concentration of Heavy Metal and Nutrients Fact of Pontian Johor Cerithidea Obtusa

J. Appl. Environ. Biol. Sci. 2017 7(12): 49-54. [\[Abstract\]](#) [\[Full-Text PDF\]](#) [\[Full-Text XML\]](#)

Aysun TUNA, Parisa GOKER

Evaluating Landscape Design Projects of Archaeological Heritage: The Case Study of Turkey

J. Appl. Environ. Biol. Sci. 2017 7(12): 55-61. [\[Abstract\]](#) [\[Full-Text PDF\]](#) [\[Full-Text XML\]](#)

Nnaji J. C., Uzairu A. and Gimba C. E.

Fractionation of Metals in Water and Bed Sediments of a Chicken-fish System

J. Appl. Environ. Biol. Sci. 2017 7(12): 62-68. [\[Abstract\]](#) [\[Full-Text PDF\]](#) [\[Full-Text XML\]](#)

Asad Mehmood, Insaf Ullah, Noor-UI-Amin, Arif Iqbal Umar, Sultan Ullah, Ali Imran Jehangiri

Public Verifiable Generalized Authenticated Encryption (PPGAE) based on Hyper Elliptic Curve

J. Appl. Environ. Biol. Sci. 2017 7(12): 69-73. [\[Abstract\]](#) [\[Full-Text PDF\]](#) [\[Full-Text XML\]](#)

Mirni Lamid, Anam Al-Arif, Sunaryo Hadi Warsito

Combination of Rice Bran with Phytase Enzymes and Menhaden Fish Oil to Increase the Essential Fatty Acids (Omega-6) in Broiler Meat

J. Appl. Environ. Biol. Sci. 2017 7(12): 74-76. [\[Abstract\]](#) [\[Full-Text PDF\]](#) [\[Full-Text XML\]](#)

Ngo Kea Leng, Juliana Mohd Nor, Che Wan Khalidawaty Khalid

The Effectiveness of Using Mnemonics Innovation for Learning Preposition of Time

J. Appl. Environ. Biol. Sci. 2017 7(12): 77-80. [\[Abstract\]](#) [\[Full-Text PDF\]](#) [\[Full-Text XML\]](#)

Arsalan Ahmed, Jianzhong Shao, Nazakat Ali, Pirah Ayaz, S Salvia Binte Touhid, Sajad Ali, Sumera Nazish, Ayaz Ahmad

Performance of Activated Sludge Biofilms Fluidized Process in The Biotreatment of Real Textile Wastewater

J. Appl. Environ. Biol. Sci. 2017 7(12): 81-90. [\[Abstract\]](#) [\[Full-Text PDF\]](#) [\[Full-Text XML\]](#)

Heba Ali Nasr and Olfat Mahmoud Nassar

Efficacy of Aqueous Extracts of Some Common Saudi Spices as a Novel Anticancer Agents against Some Human Cancer Cell Lines

J. Appl. Environ. Biol. Sci. 2017 7(12): 91-99. [\[Abstract\]](#) [\[Full-Text PDF\]](#) [\[Full-Text XML\]](#)

Hidayatus Sya'diyah, Bambang Widjanarko Otok, Puji Hastuti

The Measurement Model of Health Physiology, Psychology and Sociology on Elderly Using Confirmatory Factor Analysis

J. Appl. Environ. Biol. Sci. 2017 7(12): 100-105. [\[Abstract\]](#) [\[Full-Text PDF\]](#) [\[Full-Text XML\]](#)

Siti Nurhanifah Sulong, Siti Nor Fadillah Ahmad Shariff, Massyittah Omar, Muhamad Shah Kamal Ideris, Umme Umaimah Amin

Perceived Quality, Customers' Satisfaction and Post-Purchase Action in Off-Premise Catering

J. Appl. Environ. Biol. Sci. 2017 7(12): 106-113. [\[Abstract\]](#) [\[Full-Text PDF\]](#) [\[Full-Text XML\]](#)

Farida

The Effect of Foaming Firewood on Incision Wound Healing in Female White Rats (*Rattus Norvegicus*) Wistar Strains

J. Appl. Environ. Biol. Sci. 2017 7(12): 114-119. [\[Abstract\]](#) [\[Full-Text PDF\]](#) [\[Full-Text XML\]](#)

Suryanti Suryanti, Churun Ain, Nurul Latifah and Sigit Febrianto

Mapping of Sea Urchin Abundance as Control of Algae Expansion for the Balance of Coral Reef Ecosystem in Karimunjawa Islands

J. Appl. Environ. Biol. Sci. 2017 7(12): 120-127. [\[Abstract\]](#) [\[Full-Text PDF\]](#) [\[Full-Text XML\]](#)

Sajjad Hussain, Dr. Muhammad Munir Kayani, Dr. Zarina Akhtar

An Exploratory Study on Assessment Literacy of Teacher Educators in Pakistan

J. Appl. Environ. Biol. Sci. 2017 7(12): 128-133. [\[Abstract\]](#) [\[Full-Text PDF\]](#) [\[Full-Text XML\]](#)

Nik Noor Afizah Azlan, Nasiha Abdullah, Ain Fadhilah, Ahmad Suffian Mohd Zahari

The Organizational Commitment towards Employee's Performance: A Case Study at Elektro Serve (M) Sdn Bhd

J. Appl. Environ. Biol. Sci. 2017 7(12): 134-145. [\[Abstract\]](#) [\[Full-Text PDF\]](#) [\[Full-Text XML\]](#)

Hamdullah Jan, Prof Dr. Wazim Khan

A Study on Problems Faced by Public Sector University Libraries and its impact on their services in Khyber Pakhtunkhwa Pakistan

J. Appl. Environ. Biol. Sci. 2017 7(12): 146-151. [\[Abstract\]](#) [\[Full-Text PDF\]](#) [\[Full-Text XML\]](#)

Siti Rapidah Omar Ali, Nurzafirah Che Nordin, Nur Shafini Mohd Said, Suhaily Maizan Abdul Manaf, Wan Mardiana Wan Musa

Work Related Stressor and Job Performance among Secondary School Teachers in Malaysia

J. Appl. Environ. Biol. Sci. 2017 7(12): 152-156. [\[Abstract\]](#) [\[Full-Text PDF\]](#) [\[Full-Text XML\]](#)

Arshad Mehmood, Dr. Shamim Ali, Dr. Muhammad Shabbir, Dr. Makhdoom Ali Syed

Manipulative Role of Pakistani Print Media in Construction of Political Discourse before Elections and its Impact on Public opinion

J. Appl. Environ. Biol. Sci. 2017 7(12): 157-163. [\[Abstract\]](#) [\[Full-Text PDF\]](#) [\[Full-Text XML\]](#)

Emad Rabiei Hosseinabad and Reinaldo J. Moraga

A System Dynamics Approach in Air Pollution Mitigation of Metropolitan Areas with Sustainable Development Perspective: A Case Study of Mexico City

J. Appl. Environ. Biol. Sci. 2017 7(12): 164-174. [\[Abstract\]](#) [\[Full-Text PDF\]](#) [\[Full-Text XML\]](#)

Ngo Kea Leng, Juliana Mohd Nor, Mohd Ariff Nafizi @Ibrahim, Che Wan Khalidawaty Khalid

Comparing Dissertations Acknowledgment Pattern of Malaysian Post Graduates

J. Appl. Environ. Biol. Sci. 2017 7(12): 175-179. [\[Abstract\]](#) [\[Full-Text PDF\]](#) [\[Full-Text XML\]](#)

Waqas Ahmad, Dr. Muhammad Shabbir Ch., Uzma Niaz

People's Perceptions towards "Honor Killing": An Evidence from Pakistan

J. Appl. Environ. Biol. Sci. 2017 7(12): 180-185. [\[Abstract\]](#) [\[Full-Text PDF\]](#) [\[Full-Text XML\]](#)

Soffian Noor M.S., Noorsuhada M.N., Norizan M.N.

Hybrid Steel-Polypropylene Fibres Concrete

J. Appl. Environ. Biol. Sci. 2017 7(12): 186-193. [\[Abstract\]](#) [\[Full-Text PDF\]](#) [\[Full-Text XML\]](#)

Anwar Sadat, Rashid Ahmad, Insaf Ullah, Hizbullah Khattak, Sultan Ullah

Multi-Receiver Signcryption Based on Hyper Elliptic Curve Crypto System

J. Appl. Environ. Biol. Sci. 2017 7(12): 194-200. [\[Abstract\]](#) [\[Full-Text PDF\]](#) [\[Full-Text XML\]](#)

Riaz Shah, Faisal Bahadur, Noor-ul-Amin, Arif Iqbal Umer, Muhammad Javed Shad

Implementation of Multiple Thread Pools Based on Distribution of Service Times

J. Appl. Environ. Biol. Sci. 2017 7(12): 201-214. [\[Abstract\]](#) [\[Full-Text PDF\]](#) [\[Full-Text XML\]](#)

Khairunisa Nikman, Ngo Kea Leng

The Effect of Cooperative Learning in Enhancing "Drill-and-Practise and Critical-Thinking Skills" Among the Low Competent Students

J. Appl. Environ. Biol. Sci. 2017 7(12): 215-219. [\[Abstract\]](#) [\[Full-Text PDF\]](#) [\[Full-Text XML\]](#)

Abdul Shakoor, Muhammad Javed Iqbal

Discretionary Practices of Instructional Leaders for the Development of Educational Institutions

J. Appl. Environ. Biol. Sci. 2017 7(12): 220-228. [\[Abstract\]](#) [\[Full-Text PDF\]](#) [\[Full-Text XML\]](#)

Shujahat Ali, Muhammad Sohail Naeem, Syeda Zubbaria Zamir, Wei Lu

Illustration of Corporate Social Responsibility by the Hydro Independent Power Producers

J. Appl. Environ. Biol. Sci. 2017 7(12): 229-233. [\[Abstract\]](#) [\[Full-Text PDF\]](#) [\[Full-Text XML\]](#)

Dr. Muhammad Shabbir Chaudhary, Uzma Niaz, Shazia Nasim

Socio-Economic Determinants of Low Female Literacy Rate in Province Punjab, Pakistan: (An analysis of Rural Areas of Tehsil Jaranwala, District Faisalabad)

J. Appl. Environ. Biol. Sci. 2017 7(12): 234-239. [\[Abstract\]](#) [\[Full-Text PDF\]](#) [\[Full-Text XML\]](#)

Olfat Mahmoud Nassar, Heba Ali Nasr and Abd El-Nasser Ahmed Kobisi

Efficacy of some Natural and Trade Saudi Honeys as an Antibacterial agent against Multidrug Resistant (MDR) Human Bacterial Pathogens

J. Appl. Environ. Biol. Sci. 2017 7(12): 240-249. [\[Abstract\]](#) [\[Full-Text PDF\]](#) [\[Full-Text XML\]](#)

Abdul Hamid, Dr. Nadeem Haider Bukhari

Case, Agreement and Derivation of Pashto Clause

J. Appl. Environ. Biol. Sci. 2017 7(12): 250-262. [\[Abstract\]](#) [\[Full-Text PDF\]](#) [\[Full-Text XML\]](#)

Asghar Khan

Challenges to Integration of the Federally Administered Tribal Areas (FATA) in the Mainstream Governance System of Pakistan

J. Appl. Environ. Biol. Sci. 2017 7(12): 263-269. [\[Abstract\]](#) [\[Full-Text PDF\]](#) [\[Full-Text XML\]](#)

Abdul Zahoor Khan

The Dependability of Afghanistan and United States in the Fragmentation of U.S.S.R.: An Historical Investigation

J. Appl. Environ. Biol. Sci. 2017 7(12): 270-280. [\[Abstract\]](#) [\[Full-Text PDF\]](#) [\[Full-Text XML\]](#)

Noman Aftab, Dr. Samina Rashid, Dr. Syed Asghar Ali Shah

Effect of Agreeableness, Openness to Experience and Hope on Well-Being among University Teachers

J. Appl. Environ. Biol. Sci. 2017 7(12): 281-287. [\[Abstract\]](#) [\[Full-Text PDF\]](#) [\[Full-Text XML\]](#)

Ms. Asifa Mariam, Dr. Abdul Zahoor Khan

Gender Inequality and Role of Political Parties in Pakistan

J. Appl. Environ. Biol. Sci. 2017 7(12): 288-295. [\[Abstract\]](#) [\[Full-Text PDF\]](#) [\[Full-Text XML\]](#)

Irfan Ullah, Ashfaq U. Rehman, Sajjad Ali, Azra Yasmin

US War against Terror in Afghanistan: Insurgency in FATA and Implications for the Security of Khyber Pakhtunkhwa

J. Appl. Environ. Biol. Sci. 2017 7(12): 296-305. [\[Abstract\]](#) [\[Full-Text PDF\]](#) [\[Full-Text XML\]](#)

Muhammad, Umar Hyat, Eng Nasir Ghafoor Khan and Syed Akhtar Ali Shah

The Current Practices, Concerns and Willingness to Pay for Domestic Solid Waste Management Services in Urban Areas of Mardan, Pakistan

J. Appl. Environ. Biol. Sci. 2017 7(12): 306-315. [\[Abstract\]](#) [\[Full-Text PDF\]](#) [\[Full-Text XML\]](#)

Ghulam Nasir ul Haq, Prof. Dr. Rehmat Ali Farooq, Prof. Dr. Rabia Tabassum

Comparison of Multi-grade Teaching with Mono-grade teaching at Primary Level

J. Appl. Environ. Biol. Sci. 2017 7(12): 316-322. [\[Abstract\]](#) [\[Full-Text PDF\]](#) [\[Full-Text XML\]](#)

Asghar Khan, Ashfaq Ur Rehman, Rahman Ullah, and Shughla Ashfaq

An Assessment of Education Governance of Pakistan Tehreek Insaaf (PTI) Government in Khyber Pakhtunkhwa, Pakistan (2013 – 2018)

J. Appl. Environ. Biol. Sci. 2017 7(12): 323-330. [\[Abstract\]](#) [\[Full-Text PDF\]](#) [\[Full-Text XML\]](#)

Muhammad Ilyas Khan, Husnul Amin

Linking Factors to Fragmentation of Political Parties The Case of Pakistan Muslim League

J. Appl. Environ. Biol. Sci. 2017 7(12): 331-346. [\[Abstract\]](#) [\[Full-Text PDF\]](#) [\[Full-Text XML\]](#)

The Measurement Model of Health Physiology, Psychology and Sociology on Elderly Using Confirmatory Factor Analysis

Hidayatus Sya'diyah^{1*}, Bambang Widjanarko Otok², Puji Hastuti¹

¹High School Health Science Hang Tuah, Surabaya, INDONESIA

²Laboratory of Environmental and Health Statistics, Institut Teknologi Sepuluh November, Surabaya, INDONESIA

Received: August 11, 2017

Accepted: November 3, 2017

ABSTRACT

Increase in the number of elderly will need a serious handling because naturally elderly is experiencing setbacks, both physically and biology, or his mental. The increased number of elderly will also create health problems facing will be more complex especially related to the issue of aging. Efforts to produce a healthy aging population is not young and requires the cooperation of the parties. The purpose of this research examines the factors that affect the perception of the health of the elderly with logistic regression approach. The results of the study showed with CFA approach that the model of the measurement of the health of the elderly is the model fit and the indicator on the physical activity, aspects of psychology and social aspect is valid in convergence and discriminant and reliable. The greatest physical activity indicator is muscular strength, while aspects of psychology in a row is power remember and performance. The social aspects of the biggest indicators on changes interest.

KEY WORDS: Elderly, Health Physiology, Psychology, Sociology, CFA

1. INTRODUCTION

Elderly is the period of the cover in the amount of the life of a person that is the period in which the person has been depart far from the earlier period that is more enjoyable or depart from the full time benefits. Those who say the elderly are those who are aged more than 60 years [1]. The elderly generally experience various symptoms caused by the decline of biological functions, psychological, social and spiritual. This change will provide the influence on all aspects of the life of the elderly, including health [2].

According to the World Health Organization (WHO) population of elderly 2020 is estimated to reach 28,8 million people with an increase of approximately 11.3 4 and the age of the living hope 71.1 years [3]. The Central Statistics Agency population of elderly in Indonesia in 2010 rose to 9.7 % from the number of elderly it gave 23.9 million with age of living hope 66.2 %, 2013 has increased 6.6 % from the number of elderly 25 million, age living hope 69 years, while the number of elderly in East Java as much as the 4.113.847 or around 11 % of the total population of East Java.

Elderly reviewed from the physical aspect is the elderly who have undergone the process of aging the decrease of physical life that is marked with the more vulnerabilities of the body against the attacks of various diseases that can cause death, this caused along with the increase of the age of the changes occur in the structure and function of the cell, network and organ system [4]. On the psychological aspects of elderly power reduction remember, analytics or intelligence in processing information. The older people generally tend to be weak in memngingat new things learned and vice versa their memory good enough against the things that had long been studied. This is caused by the fact that they are not motivated to mengingatingat something, the lack of attention, hearing that less clearly and what he hears is different from the one spoken [1][5]. From the point of view of social, elderly is a separate social groups. In Western countries, elderly occupied social strata under the youth. For the people of traditional Asian, elderly occupied a high social class that must be respected by the community. [6] presents one of the results of research shows that 57 percent of respondennya feel religion is more meaningful for them after the pension than ever before. Another research shows that, 67-71 percent of elderly women and 52-55% in men say that religion is very important in his life, 5 percent of women and 7- 19% men say that religion does not mean much for them. From some research results indicate that religiosity increased in line with the age of the person. Further said that in some research results, confidence and trust in the Lord will alleviate the suffering when people experience sorrow, lonely, desperation or other emotional problems, in with their proximity to God can strengthen the faith and strength in each of the people (religiosity, the existence of the couple and social welfare on Elderly Binan PMI Branch Semarang.

Based on the research done by [7], titled psychological well-being and Health found that well-being has implications on the physical health. Declining physical abilities that cause various diseases and functional disorders in the elderly is not only affecting the physical condition but will affect the condition of psychological. Research Results [8], find that the elderly residents of the orphanage is very poor conditions in various aspects such as physical and psychological health, adjustments themselves and social and independence is very low. This generally means the elderly residents of the orphanage have differences with the elderly who live with the family.

Corresponding Author: Hidayatus Sya'diyah, High School Health Science Hang Tuah, Surabaya, INDONESIA.

Email: mahisyah_sht@yahoo.com

According to [9], various physical problems in the elderly are not only physical impact on the elderly but also have an impact on the physical elderly to appear some psychological problems such as anxiety, depression, insomnia, paranoid and dementia. Decline in physical function and disease suffered by the elderly cause elderly need other people to help in doing daily activities. Other problems can be derived from the social aspects and psychological aspects or emotional.

In the life of the elderly in order to maintain a healthy physical condition, it needs to be adapted to the needs of the physical needs with psychological or social conditions, so that would be no effort to reduce activities that are physical memforsir. A senior citizens must be able to set the way of life with good, for example eat and sleep rest and work in a balanced. Health education to the community, the administrator of the orphanage werdha elderly rehabilitation center managers about the importance of the independence of the elderly must always be improved. Elderly that healthy and independent will improve the quality of life of the elderly [6]. One of the ways that can be done by the elderly to face the problems is to achieve psychological kesejahteraan. Social support refers to the comfort, attention, Aliansi Jurnalis Independen, or assistance given by another person or group to the individual. Nurses can play to help the elderly in the search for meaning and help elderly in spiritual practices [10]. Lead a spiritual activity to understand the meaning of each of the rituals and still soulful positive.

Based on explanation above, this research examines the relationship of indicators physical abilities, psychological and social between the elderly using confirmatory factor analysis (CFA) [11]. According [12], CFA is not a method to find the structure of the factor, but confirm the existence of the structure of the specific factors. One of the advantages of CFA is flexibility level when applied in a model of a complex hypothesis. Estimation method in CFA used maximum likelihood which can determine the optimum value on the factor loading [13].

2. METHODOLOGY

The population in this research is the elderly in Surabaya City. Sample in research as much as 206 senior citizens in the coastal areas: Sub-districts Kenjeran and Panti Wreda: Hargo Dedali, UPT Liponosos Whitish with a method simple random sampling [14]. The latent variable in this research is the physical activity (X1), aspects of psychology (X2), the social aspects of (X3) [15]. The framework of the concept of the relationship between the latent variables served as follows.

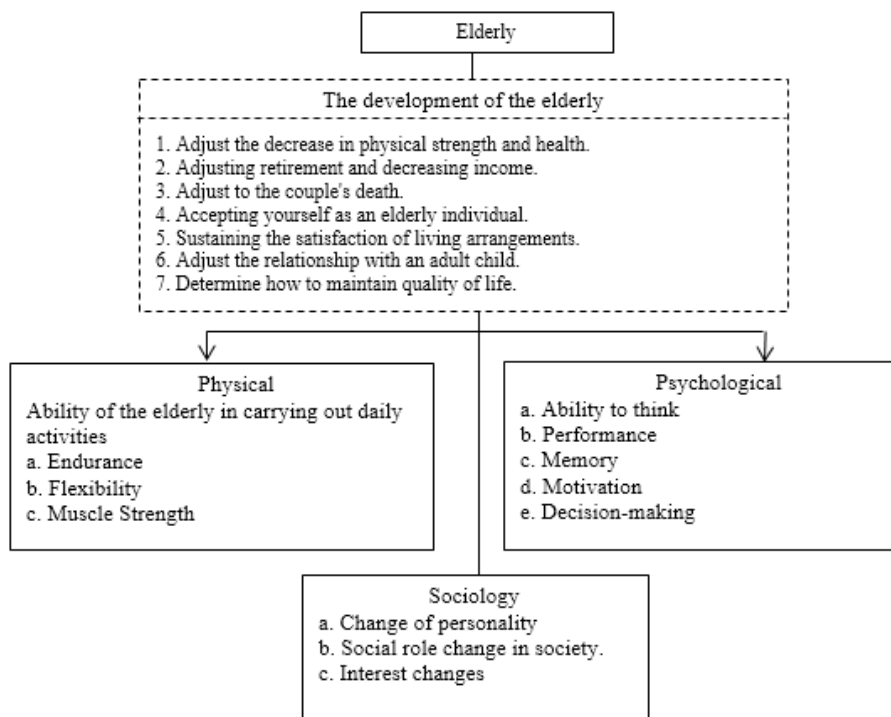

Figure 1. The Conceptual Framework the perception of the health of the Elderly [5] [9] [15]

The Data in this research using primary data through the survey. Furthermore done analysis with the method CFA. The basic principles of Confirmatory Factor Analysis is started by confirming a number of factors (the dimension of the problem) and then to each of the dimensions investigated in depth using some theoretical indicators that have the support of the theory of the strong and to test a theory or the concept of a process or a phenomenon

The measurement model of the factors presented in the picture below.

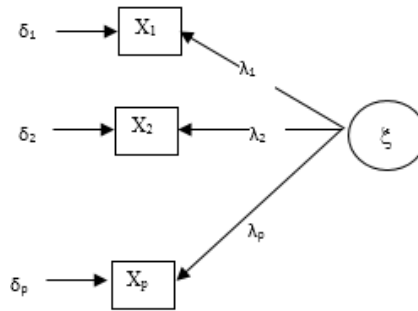

Figure 2. Measurement Model for Single Latent Variabel

In the form of a matrix can be written as:

$$\mathbf{X} = \Lambda_x \xi + \delta \tag{1}$$

where:

- \mathbf{X} : matrix indicator variable
- Λ_x : matrix lambda (loading factor)
- ξ : matrix of the latent variable
- δ : error

Suppose a latent variables can be measured by two indicators (p=2), there will be a form of equality as follows:

$$X_1 = \lambda_1 \xi + \delta_1 ; \quad X_2 = \lambda_2 \xi + \delta_2 \tag{2}$$

To know whether the indicator variable is really valid in measuring the factors or construct so that explains the dimensions of the factors done with the test statistics t. The use of t tests is due to the loading factor (λ_i) in confirmatory factor analysis using standardized estimate as massive regression [12]. The hypothesis that is used is as follows:

$H_0 : \lambda_i = 0$ (loading factor is not significant in measuring the latent variable)

$H_1 : \lambda_i \neq 0$ (loading factor significant in measuring the latent variable)

where $i = 1, 2, \dots, p$ is indicator variable.test statistics for loading factor is.

$$t = \frac{\hat{\lambda}_i}{\hat{S}(\hat{\lambda}_i)} \tag{3}$$

Where :

$\hat{\lambda}_i$: estimator loading factor

$$\hat{S}(\hat{\lambda}_i) = \sqrt{\frac{\hat{\sigma}^2}{\sum_{i=1}^n (X_i - \bar{X})^2}}$$

$\hat{\sigma}^2$: Varians of observation variable X

When $|t| > t_{\alpha,df}$ then reject H_0 and estimation of relationship causal parameters (regression coefficient) significant in measuring the relationship of causation is so formed by unidimension.

3. RESULTS AND DISCUSSION

Variable frequency distribution research, namely the perception of the health of the elderly, health physical, psychological, social relations and the environment is presented in the following table.

Table 1. Description of the research Variables

Latent Variable (indicator)	Mean	Standard deviation
Physical Health		
X1.1 (durability)	3.7788	.89323
X1.2 (malleability)	3.5356	.83633
X1.3 (muscular strength)	3.4173	.86478
Aspects of Psychology		
X2.1 (ability to think)	3.6982	.66448
X2.2 (performance)	3.7654	.72776
X2.3 Power (remember)	3.8350	.65953
X2.4 (motivation)	3.9912	.63046
X2.5 (decision making)	3.7240	.61608
Social Aspects		
(X3.1 Personality changes)	3.9238	.64533
X3.2 (social change in society)	3.9668	.66932
X3.3 (changes interest)	3.7477	.64789

Table 1 shows that a good physical health more perceptions of the health of the elderly in a positive (94.3%), a good psychological more have elderly health perception of positive (80.6%), a good social relationship more have elderly health perception of positive (86.3%), and good environment more have elderly health perception of positive (90.0%).

Physical health relationship, psychology, social and environmental relationship with the perception of the health of the elderly is done with validity convergence, validity discriminant and reliability. The results of analysis presented in the following table.

Table 2. Convergence validity and reliability of the indicators on physical activity, aspects of Psychology, Social Aspects

Latent Variable	Indicators	Validity Convergence			Reliability			Composite Reliability
		Loading Factor	P-value	Description	Error Variance	P-value	Description	
Physical Activity	X1.1 (durability)	0.736	0.000	Valid	0.364	0.000	Reliabel	0.780
	X1.2 (malleability)	0.661	0.000	Valid	0.392	0.000	Reliabel	
	X1.3 (muscular strength)	0.761	0.000	Valid	0.313	0.000	Reliabel	
Aspects of Psychology	X2.1 (ability to think)	0.551	0.000	Valid	0.306	0.000	Reliabel	0.866
	X2.2 (performance)	0.828	0.000	Valid	0.166	0.000	Reliabel	
	X2.3 Power (remember)	0.830	0.000	Valid	0.134	0.000	Reliabel	
	X2.4 (motivation)	0.809	0.000	Valid	0.137	0.000	Reliabel	
	X2.5 (decision making)	0.585	0.000	Valid	0.248	0.015	Reliabel	
Social aspects	X3.1 (Personality changes)	0.691	0.000	Valid	0.217	0.000	Reliabel	0.839
	X3.2 (social change in society)	0.604	0.000	Valid	0.283	0.000	Reliabel	
	X3.3 (changes interest)	0.858	0.000	Valid	0.110	0.000	Reliabel	

Table 2 shows that all indicators in each latent variable are valid and reliable. This is shown in the loading value which is all more than 0.5 and also of the p-value value of the validity convergence and reliability is smaller than $\alpha = 0.05$. Furthermore, the reliability of each latent variable can also be said reliably, it is shown from the value of composite reliability greater than 0.7. The X1.3 (muscular strength) (0.761) and X1.1 (durability) (0.736) indicator are the dominant formers of the latent variable Physical Activity, whereas in Aspects of Psychology the dominant shaper of the X2.3 Power (remember) (0.830), X2.2 (performance) (0.828), and X2.4 (motivation) (0.809) indicator. For social aspect, X3.3 (changes interest) is the dominant form of 0858.

Table 3. Validity Discriminant on Physical Activity, Aspects Psychology, Social Aspects

Covariance	Discriminant Validity				
	Estimator	Standard Error	Critical Ratio (CR)	p-value	Description
Physical activity with aspects of Psychology	.014	.020	.719	.472	Valid
Psychological aspects with social aspects	.054	.038	1.429	.317	Valid
Physical activities with social aspects	.097	.072	1350	.298	Valid

Table 3 shows that the estimated value of covariance between Physical activity with aspects of Psychology is 0.014 with p-value of 0.472, between Psychological aspects with social aspects of 0.054 with p-value of 0.317, and between Physical activities with social aspects of 0.097 with p-value of 0.298. This shows the relationship between the latent variables Physical activity, the aspects of Psychology and social aspects give p-value greater than $\alpha = 0.05$, and this can be said that the assumption of discriminant validity has been met.

Diagram of the relationship between the latent variable in detail is presented in the following figure.

**CONFIRMATORY FACTOR ANALYSIS
PHYSICAL ACTIVITY, PSYCHOLOGY & SOCIAL ASPECTS**

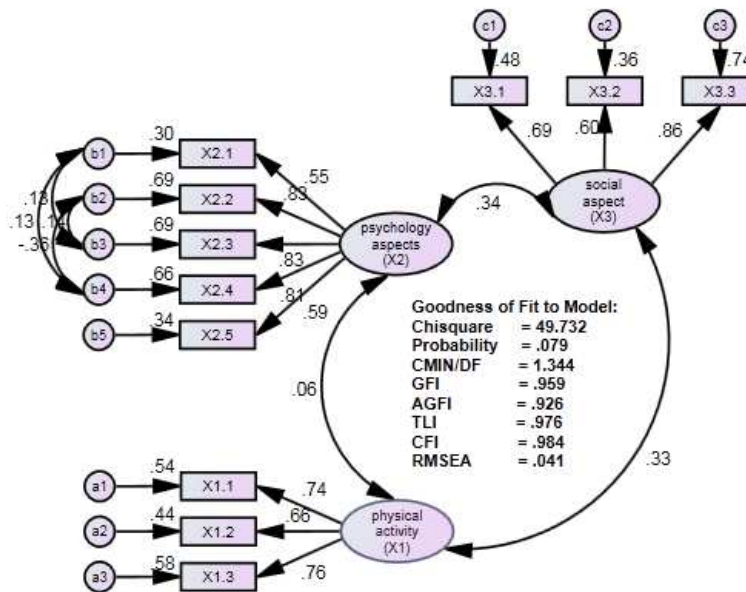

Figure 3. The Relationship of physical activity, Psychology and Social Aspects

Goodness of Fit Model of the Measurement of Health Elderly

The results of the measurement model testing with AMOS program in detail can be seen in the following table:

Table 4. Results Model Testing Measurement of Health Elderly

The criteria	Cut – Off Value	Results	Description
Chi - Square	expected small	49.732	χ^2 with df 37 is 52.192 Good
Probability	≥ 0.05	0.079	Good
RMSEA	≤ 0.08	0.041	Good
GFI	≥ 0.90	0.959	Good
AGFI	≥ 0.90	0.926	Good
CMIN/df	≤ 2.00	1.344	Good
TLI	≥ 0.95	0.976	Good
CFI	≥ 0.95	0.984	Good

Figure 3 and Table 4 showed that the 8 (eight) criteria used to assess worthy / or not a good model it states. It can be said that the measurement model for the validity and discriminant convergen acceptable, which means there is a similarity between the model with data.

4. CONCLUSION

The results of the study showed with CFA approach that the model of the measurement of the health of the elderly is the model fit and the indicator on the physical activity, aspects of psychology and social aspect is valid in convergence and discriminant and reliable. The greatest physical activity indicator is X1.3 (muscular strength), while aspects of psychology in a row is X2.3 (power remember) and X2.2 (performance). The social aspects of the biggest indicators on X3.3 (changes interest).

REFERENCES

[1] Efendi, Ferry & Makhfud. (2009). *Keperawatan Kesehatan Komunitas Teori dan Praktik dalam Keperawatan*. Jakarta: Salemba Medika

[2] Tamher, S. Noorkasiani. (2011). *Kesehatan Usia Lanjut dengan Pendekatan Asuhan Keperawatan*. Salemba Medika. Jakarta

[3] Nugroho, H. Wahyudi, B.Sc., SKM. 2008. *Keperawatan Gerontik & Geriatrik*. Edisi 3. Jakarta: penerbit buku kedokteran EGC.

- [4] Notoatmodjo, S (2007). *Promosi Kesehatan dan Ilmu Perilaku*. Jakarta: Rineka Cipta.
- [5] Darmojo B. 2009. *Geriatric Ilmu Kesehatan Usia Lanjut*. Edisi keempat. Jakarta: Balai Penerbit FKUI
- [6] Pratiwo, Suryo, dkk (2012). *Analisis Pengaruh Faktor Nilai Hidup, Kemandirian, dan Dukungan Keluarga Terhadap Prilaku Sehat Lansia Di Kelurahan Medono Kota Pekalongan*. *Jurnal Promosi Kesehatan Indonesi Vol.1/No.2*. Semarang: UNDIP.
- [7] Ngali, Purwanto (2002). *Psikologi Pendidikan*. Bandung: PT. Remaja Rosdakarya.
- [8] Carson RC, Juszcsek M, Davenport A, Burns A. 2009. Is maximum conservative management an equivalent treatment option to dialysis for elderly patients with significant comorbid disease. *Clin J Am Soc Nephrol*; 4: 1610 – 19
- [9] Maryam, R. Siti & dkk (2008). *Mengenal Usia Lanjut dan Perawatannya*. Jakarta: Salemba Medika.
- [10] Helene L. Lipton, Philip Randolph Lee, and Mark S Freeland, 1988. *Drugs and the Elderly; Clinical, Social and Policy Perspectives*
- [11] Brown, T. A., (2006). *Confirmatory Factory Analysis for Applied Research*. The Guilford Press, New York.
- [12] Hidayat, R.N, Suhadak, Darminto, Siti, R.H., Bambang W.O., (2014). Measurement Model of Service Quality, Regional Tax Regulations, Taxpayer Satisfaction Level, Behavior and Compliance Using Confirmatory Factor Analysis, *World Applied Sciences Journal* 29 (1): 56-61. © IDOSI Publications.
- [13] Mulaik, S.A, (2009), *Linear Causal Modeling with Structural Equation*, Chapman and Hall, USA
- [14] Levy, P.S., and Stanley, L. (1999). *Sampling of Populations: Methods and Applications*. Third Edition. John Wiley and Sons. Inc. New York.
- [15] Kahana, E, (2009). *Elderly Care Research Center Case Western Reserve University*. Department of Sociology. 10900 Euclid Avenue.

INSTRUCTION TO AUTHORS

Manuscript Submission:

Send your manuscript with attachment by mailing it to info@textroad.com, textroadjournals@gmail.com along with [covering letter](#).

Manuscript Preparation:

- * Title
- * Author names and addresses
- * Abstracts (Not more than 300 words)
- * Key words
- * Introduction
- * Materials and Methods
- * Results and Discussions
- * References (Use numbering in the text instead of full references).
Give full references at the end of the file
- * Photographs should be of high quality (Minimum 300-600 dpi)
- * Graphs should be in clearly visible form so that it may become easy to redraw
- * The manuscript must be submitted in MS-WORD file format.

INSTRUCTIONS TO AUTHORS

Submission

Submit manuscripts as e-mail attachment to the Editorial Office at:

textroadjournals@gmail.com or info@textroad.com along with [covering letter](#). A manuscript number will be mailed to the corresponding author same day or within 48 hours. The authors may also suggest two to four reviewers for the manuscript (JBASR may designate other reviewers). There is no page limit. The submitting author takes responsibility for the paper during submission and peer review.

Terms of Submission

Papers must be submitted on the understanding that they have not been published elsewhere (except in the form of an abstract or as part of a published lecture, review, or thesis) and are not currently under consideration by another journal. The submitting author is responsible for ensuring that the article's publication has been approved by all the other coauthors. All enquiries concerning the publication of accepted papers should be addressed to editor@textroad.com.

Review Process

All manuscripts are reviewed by an editor and members of the Editorial Board or qualified outside reviewers. Decisions will be made as rapidly as possible, and the journal strives to return reviewers' comments to authors within one or two weeks. The editorial board will re-review manuscripts that are accepted pending revision. It is the goal of the JBASR to publish manuscripts within 4 weeks after submission.

Style of Manuscripts

Manuscripts should be written in clear, concise and grammatically correct English (with 10 font size and Times New Roman font style) so that they are intelligible to the professional reader who is not a specialist in any particular field. Manuscripts that do not conform to these requirements and the following manuscript format may be returned to the author prior to review for correction. The entire manuscript, including references, should be typed single spaced on one side of the paper. All pages should be numbered consecutively in the bottom centre starting from the title page. The manuscript should be presented in the following order.

Title and Authorship Information

The title should be a brief phrase (capitalize first letter of each word in the title) describing the contents of the paper. The Title Page should include the authors' full names and affiliations, the name of the corresponding author along with phone, fax and E-mail information. Present addresses of authors should appear as a footnote.

Abstract

All manuscripts should not exceed 250-300 words and should describe the scope, hypothesis or rationale for the work and the main findings. Complete sentences, active verbs, and the abstract should be written in the past tense. Standard nomenclature should be used and abbreviations should be avoided. No literature should be cited.

Keywords

Key words (5-7 words) should be provided below the Abstract to assist with indexing of the article. These should not duplicate key words from the title.

Introduction

This section should include sufficient background information, provide a clear statement of the problem, the relevant literature on the subject, and the proposed approach or solution. The aims of the manuscript should be clearly stated. The introduction should not contain either findings or conclusions. It should be understandable to colleagues from a broad range of scientific disciplines.

Materials and Methods

This should be complete enough to provide sufficient detail to allow the work to be repeated by others. However, only truly new procedures should be described in detail; previously published procedures should be cited, and important modifications of published procedures should be mentioned briefly. Capitalize trade names and include the manufacturer's name and address. Subheadings should be used. Methods in general use need not be described in detail.

Results

Results should be presented in a logical sequence in the text, tables and figures; repetitive presentation of the same data in different forms should be avoided. The results should not contain material appropriate to the Discussion. It should be written in the past tense when describing findings in the authors' experiments. Results should be explained, but largely without referring to the literature.

Discussion

The discussion should consider the results in relation to any hypotheses advanced in the Introduction and place the study in the context of other work. Results and Discussion sections can be combined.

Conclusions

If an optional conclusion section is used, its content should not substantially duplicate the abstract.

Acknowledgment

The acknowledgments of people, grants, funds, etc should be brief.

References

Bibliographic references in the text appear like [1, 2, 5, 6], using square brace in superscript. References should be numbered consecutively, with style:

Journal paper:

1. Hadjibabaie, M., N. Rastkari, A.Rezaie and M. Abdollahi, 2005. The Adverse Drug Reaction in the Gastrointestinal Tract: An Overview. Intl. J. Pharmacol., 1 (1): 1-8.

Books:

1. Daniel A. Potter, 2002. Destructive turfgrass insects: Biology, diagnosis and control. Wiley Canada Publishers, pp: 24-67.

Chapters in Book:

1. Bray R.A., 1994. The leucaena psyllid. In: Forage Tree Legumes in Tropical Agriculture (eds R.C. Gutteridge and H.M. Shelton) pp. 283-291. CAB International, Oxford.

Titles of journals should be given in full. 'In press' can only be used to cite manuscripts actually accepted for publication in a journal. Citations such as 'manuscript in preparation' or 'manuscript submitted' are not permitted. Data from such manuscripts can only be mentioned in the text as 'unpublished data'.

A Report:

1. Makarewicz, J.C., T. Lewis and P. Bertram, 1995. Epilimnetic phytoplankton and zooplankton biomass and species composition in Lake Michigan, 1983-1992. U.S. EPA Great Lakes National Program, Chicago, IL. EPA 905-R-95-009.

Conference Proceedings:

1. Stock, A., 2004. Signal Transduction in Bacteria. In the Proceedings of the 2004 Markey Scholars Conference, pp: 80-89.

A Thesis:

1. Strunk, J.L., 1991. The extraction of mercury from sediment and the geochemical partitioning of mercury in sediments from Lake Superior, M. S. thesis, Michigan State Univ., East Lansing, MI.

Tables and Equations

Tables and equations should not be submitted in a format exceeding the A4 page size (in portrait form). **All tables should be embedded within the manuscript, and must be captioned and numbered sequentially.** Each table should be on a separate page, numbered consecutively in Arabic numerals and supplied with a heading and a legend. Tables should be self-explanatory without reference to the text.

Figures / Illustrations / Photographs

Graphics should be supplied as high resolution (at least 300-600 dp.i.) electronic files. Digital images supplied only as low-resolution print-outs cannot be used. Graphs, diagrams, chromatograms, photos, etc. should be prepared as clear, original positives, suitable for reproduction. **All figures should be embedded within the manuscript, and must be captioned and numbered sequentially.**

Proofs

Proofs will be sent via e-mail as an Acrobat PDF file (e-mail attachment) and should be returned within 3 days of receipt. Page proofs are considered to be the final version of the manuscript. With the exception of typographical or minor clerical errors, no changes will be made in the manuscript at the proof stage.

Check List

We recommend that you ask a colleague to read over your paper prior to submission to ensure it is of a high standard and conforms to a high level of scientific writing.

Before submission of your manuscript, please check that:

- All references cited in the text are included in the reference section.
- All figures and tables are cited in the text.
- Figures are at least 300 d.p.i.
- The pages are numbered.



[Home](#)

[Journals](#)

[Instructions to Authors](#)

[Manuscript Submission](#)

[Join Us](#)

[Contact Us](#)



Journal of Basic and Applied Scientific Research



Journal of Social Sciences and Humanity Studies



Journal of Basic and Applied Chemistry



Journal of Basic Sciences and Applied Research



Journal of Applied Environmental and Biological Sciences



Journal of Computer Sciences and Communication



Journal of Pharmaceutical and Biomedical Sciences



Journal of Engineering and Higher Technology



Journal of Agriculture and Food Technology



Current Economics and Management Research

MISSION
TEXTROAD journals provide free access to worldwide quality research publication. Our programs present a rapid time possible for reviewing and publishing. TEXTROAD journals are well indexed/abstracted in the world's known databases. Our editorial team members spread in different corners of the world and make sure of the quality of the published research articles.

VISION
To publish descriptions of all aspects of basic and applied research having an important value worldwide. Our journals publish peer-reviewed original research, critical reviews, or short communications in all aspects of basic, applied and advanced research.

GOALS
The ultimate goals of these journals are to help scientists and researchers, especially those from developing countries, publish their best findings in our scientific journals. Also, offer scientific technical and consultants service to the publishing services.